



## Introduction

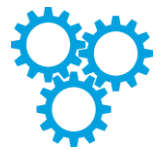
This manual is intended to provide a description of the installation procedure for the LAN CONNECT ftp data server.

## Requirements

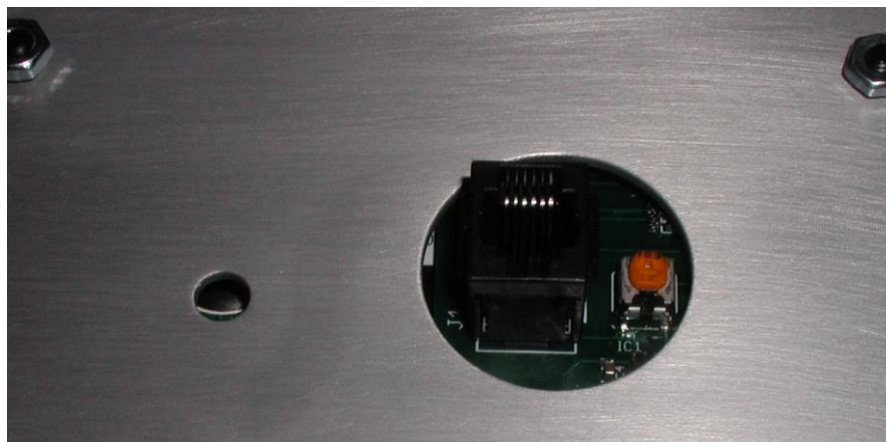
The LAN-USB CONNECT device will work with a CNC control with a standard DB25 RS-232 serial connection to the control box for the purposes of input/output of CNC data. Typically, the CNC manufacturer refers to this as read and punch tape functions.

**NOTE:** Please see last page of this document for a Mounting Template

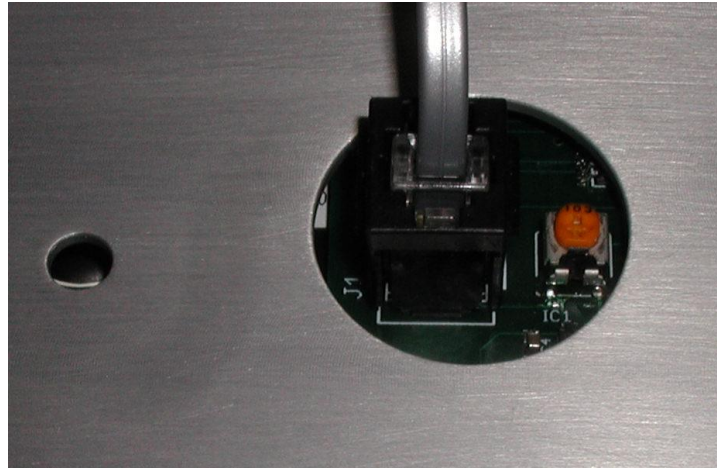
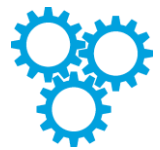
**Please review the instruction manual thoroughly before beginning installation. In addition, the installer should verify that proper space and clearance has been taken into account prior to drilling holes in the CNC pendant. This includes cable bending radius and cable length.**



Mount the display and bracket to the control box.



Inside the cabinet the RJ11 and the potentiometer should be visible through the large diameter hole.

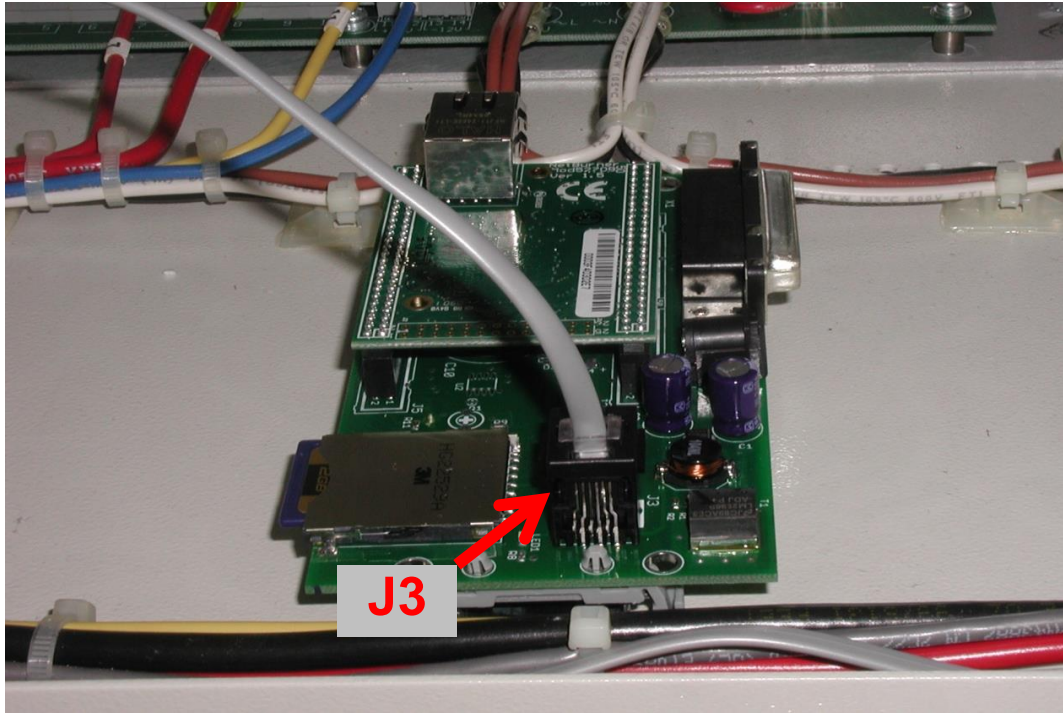


Plug the modular cable into the RJ11 jack. Note the length of the cable. The LAN CONNECT controller board will need to be within the distance of the cable length when mounted.

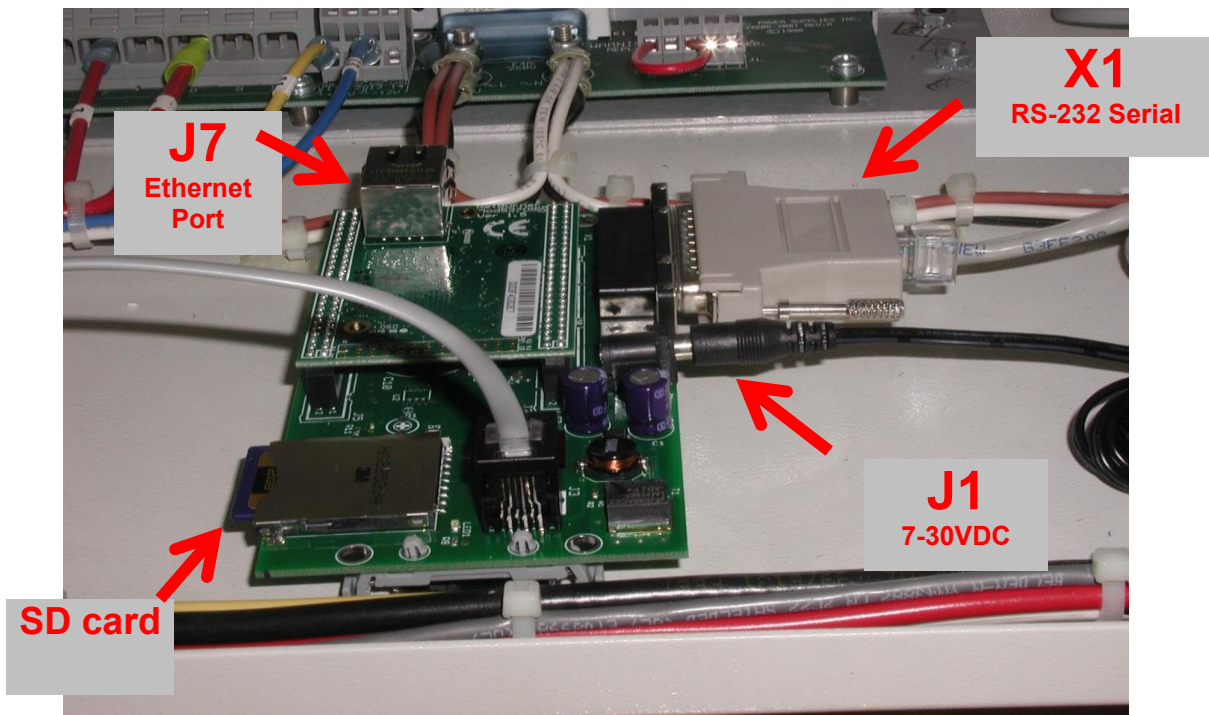
Locate a good position for the LAN CONNECT controller board. It will need to be within the distance of the display cable, serial cable and the power plug. Secure the din rail as shown below.



Attach the din rail clips to the LAN CONNECT controller and mount to the din rail. Check for spacing. The two outer holes from the din rail clips can be used to release from the clips with a small screwdriver.



Plug the modular cable from the display into the RJ11 connector **J3** on the LAN CONNECT controller board.







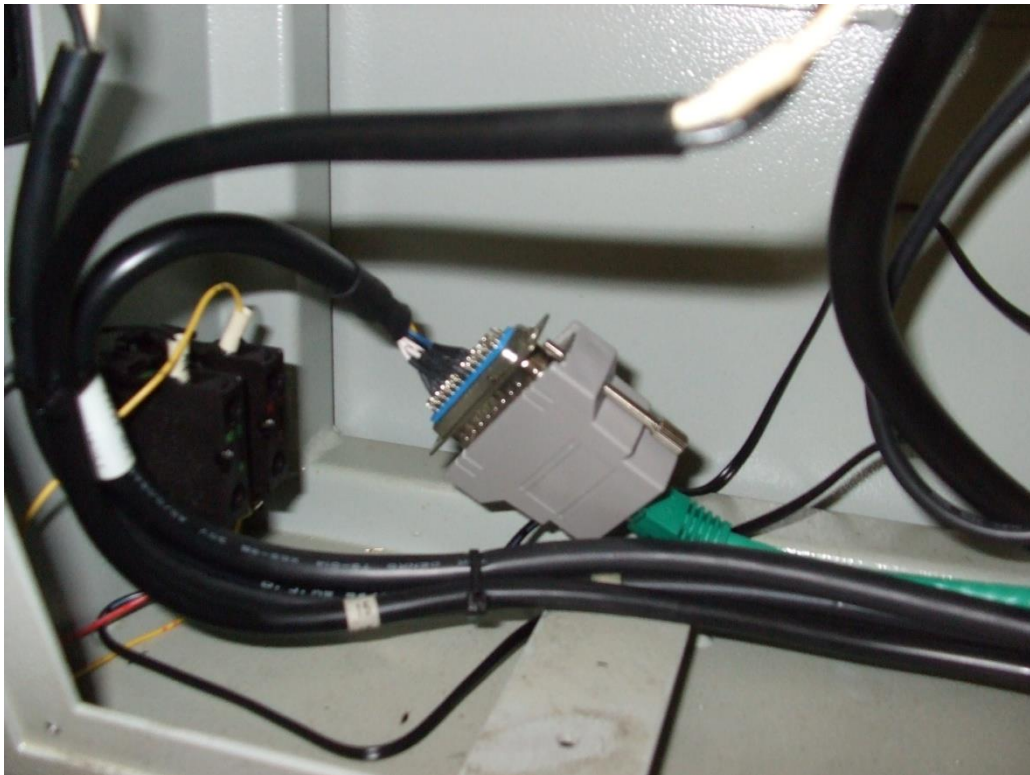
Note: uses standard CAT5 patch cable as a RS-232 cable. Do not confuse this with the LAN CAT5 that is used with the Ethernet network that connects to the LAN CONNECT at J7. Plug the RS-232 RJ45/DB25 plug into the X1 DB25F on the control board. The control board uses a straight cable connection. The Null modem is hardwired on the LAN CONNECT control board. The other end of the CAT5 cable will plug into the RJ45/DB25 plug later in the installation.

Plug the round DIN power plug into **J1** on the control board shown above. The control board requires any voltage between 7-30VDC to operate. The center is +VDC and the outside barrel of the plug is ground. Test the voltage and polarity before plugging into the LAN CONNECT board.

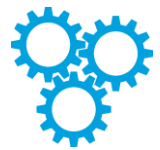
Plug the network Ethernet cable from the LAN network directly into the silver **J7** RJ45 connector on the small daughter board.

Make sure the SD card is latched into the SD card housing. Pressing the SD card in will eject the card. Pressing the SD card in again will latch the card.

Locate the serial port connector of the CNC. Attach one end of the CAT5 cable to the serial port connector of the LAN CONNECT controller. Attach the other end to one of the DB25 connectors included with the kit. Both male and female connectors have been provided. Choose one as appropriate. In most cases, it is best to simply pull the serial connector in from its mounting assembly and connect inside the pendant as shown below.

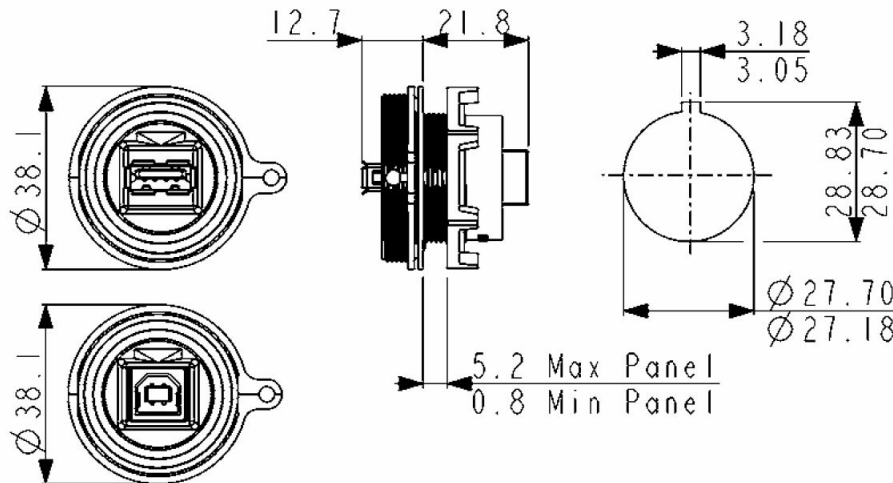


**Figure 1**



In addition, you will need to install the USB cable from the unit to the outside of the machine, so the USB port may be used.

Choose a location for the panel mounted USB plug. Its location should be chosen for convenient connection of a USB key during normal operation of the machine. Punch a hole in the desired location to the dimensions shown below. Insert the panel mount USB connector through the hole and secure with the attached nut. Ensure that the gasket included with the kit is used to prevent contaminants from entering the enclosure. The cap of the panel mount USB connector snaps onto the connector house. (Note: the A side of the USB connector faces out of the pendant while the square B side of the USB connector faces into the pendant). Connect the USB plug to the controller with the USB cable provided.



Connect the power plug provided to the printed circuit board. The power connection is center positive. The positive wire is identified with a white-stripe running the full length of the wire. The solid black wire should be connected to ground. As discussed previously, the power supply can be anywhere in the range of 7-30 volts DC. Find a suitable power source in the cabinet and connect the flying lead connections to a power source. Apply power to the unit. A green LED should illuminate on the controller indicating that power has been applied. If properly connected, the keypad will also illuminate after a slight delay.

### To Adjust the Display Contrast

An orange potentiometer (**R2**) located on the back of the display board can be used to adjust the contrast of the keypad display. This potentiometer should be accessible through the large diameter hole in the control box

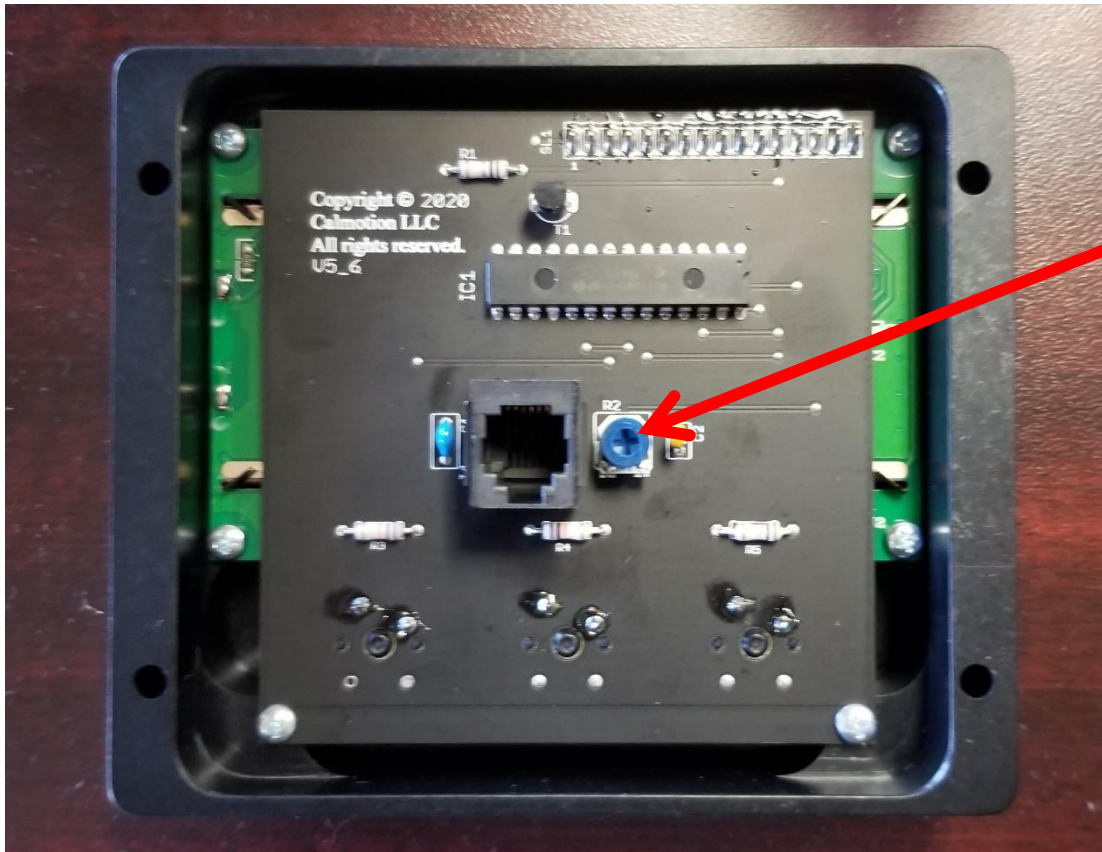
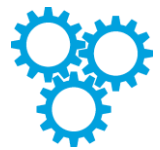


Figure 2

Please refer to the LAN-USB CONNECT user’s manual for operation and communication set-up of the LAN CONNECT.